

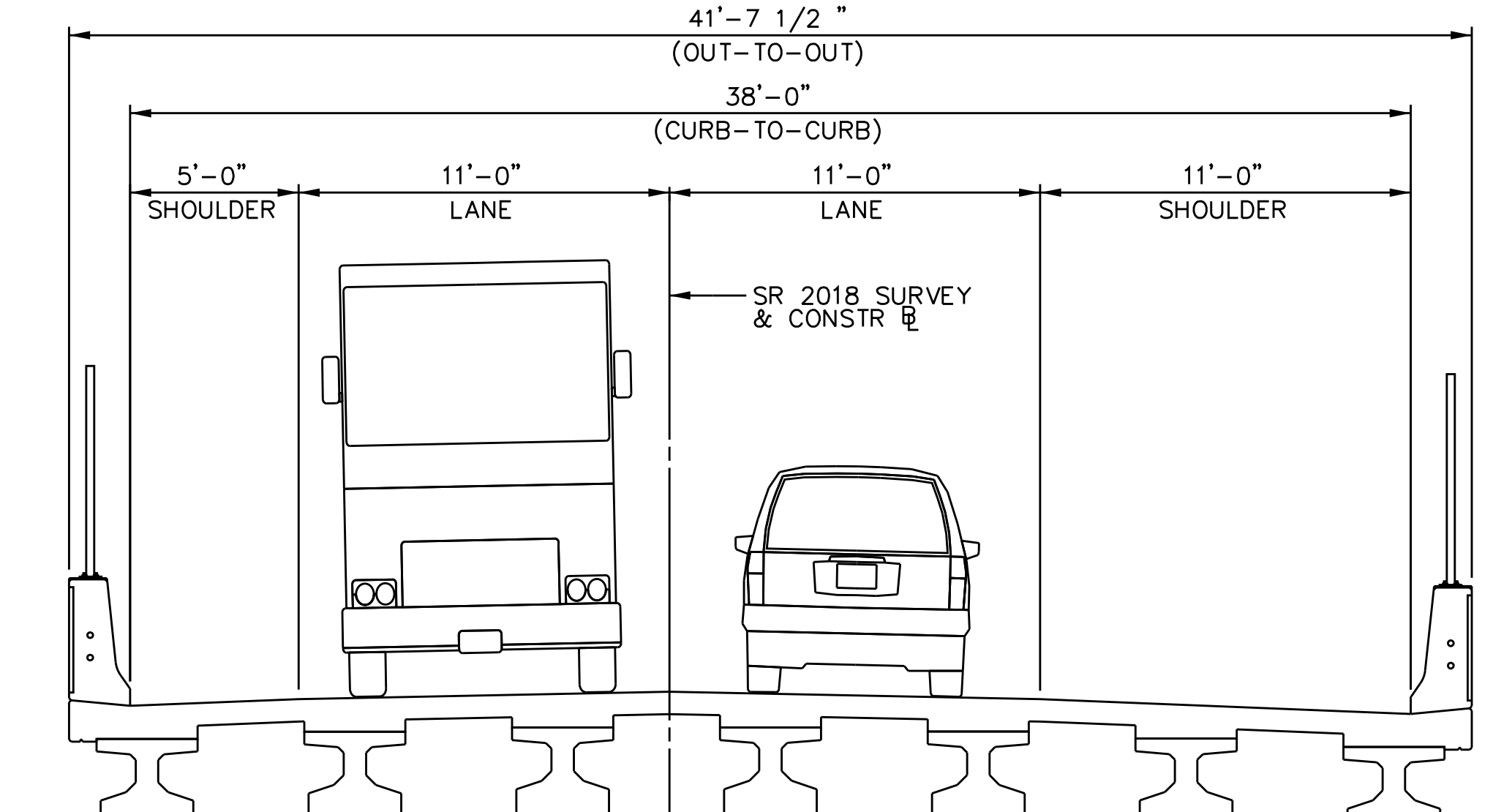

Indian Creek Road Bridge (SR 2018)

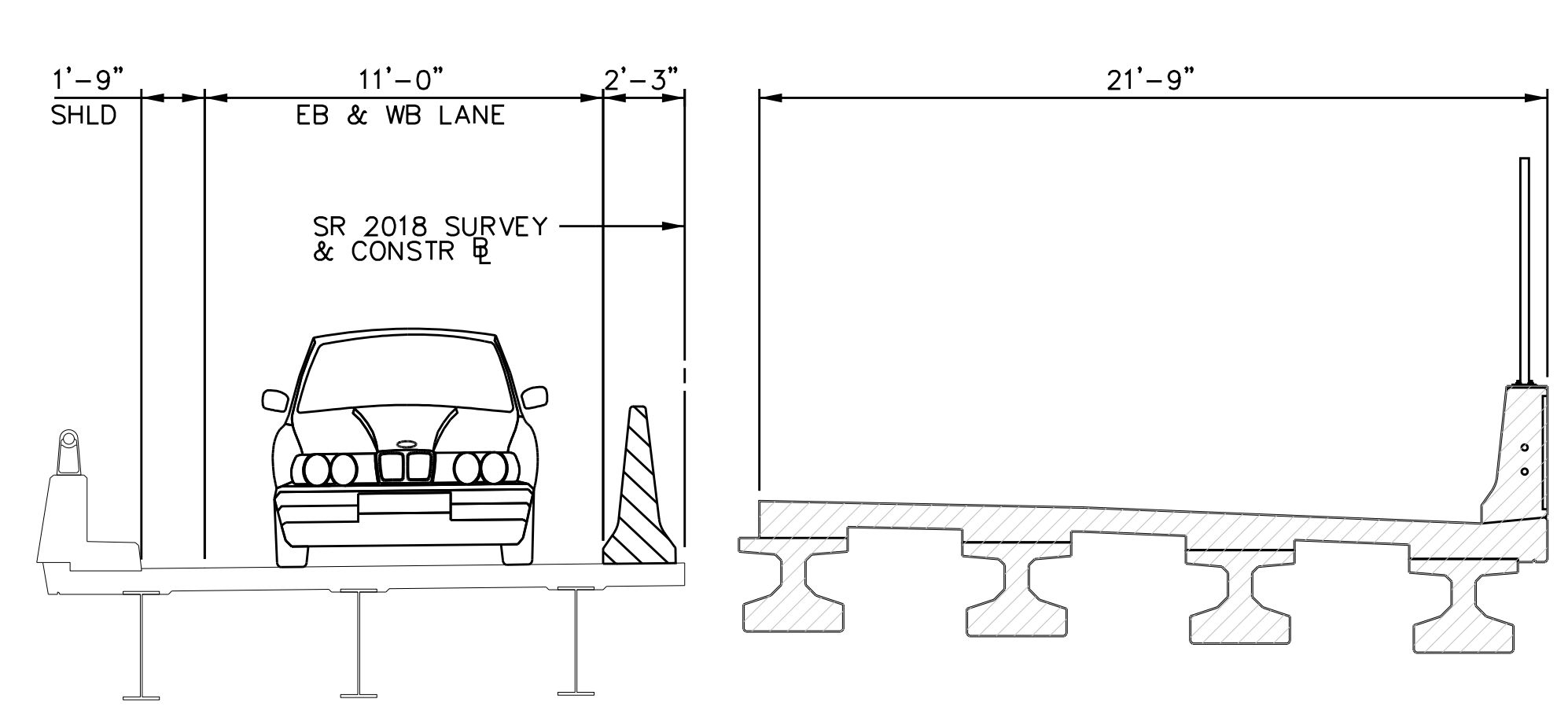
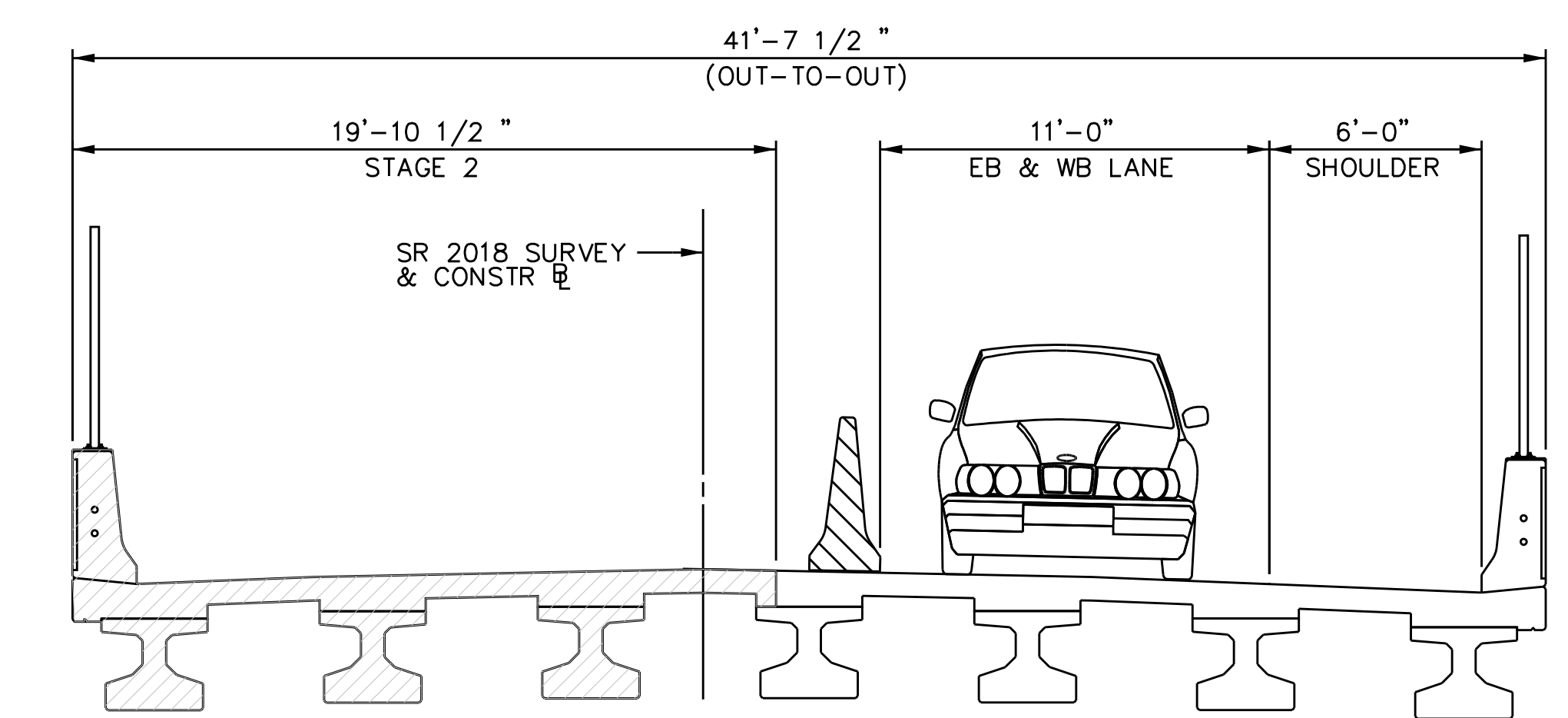
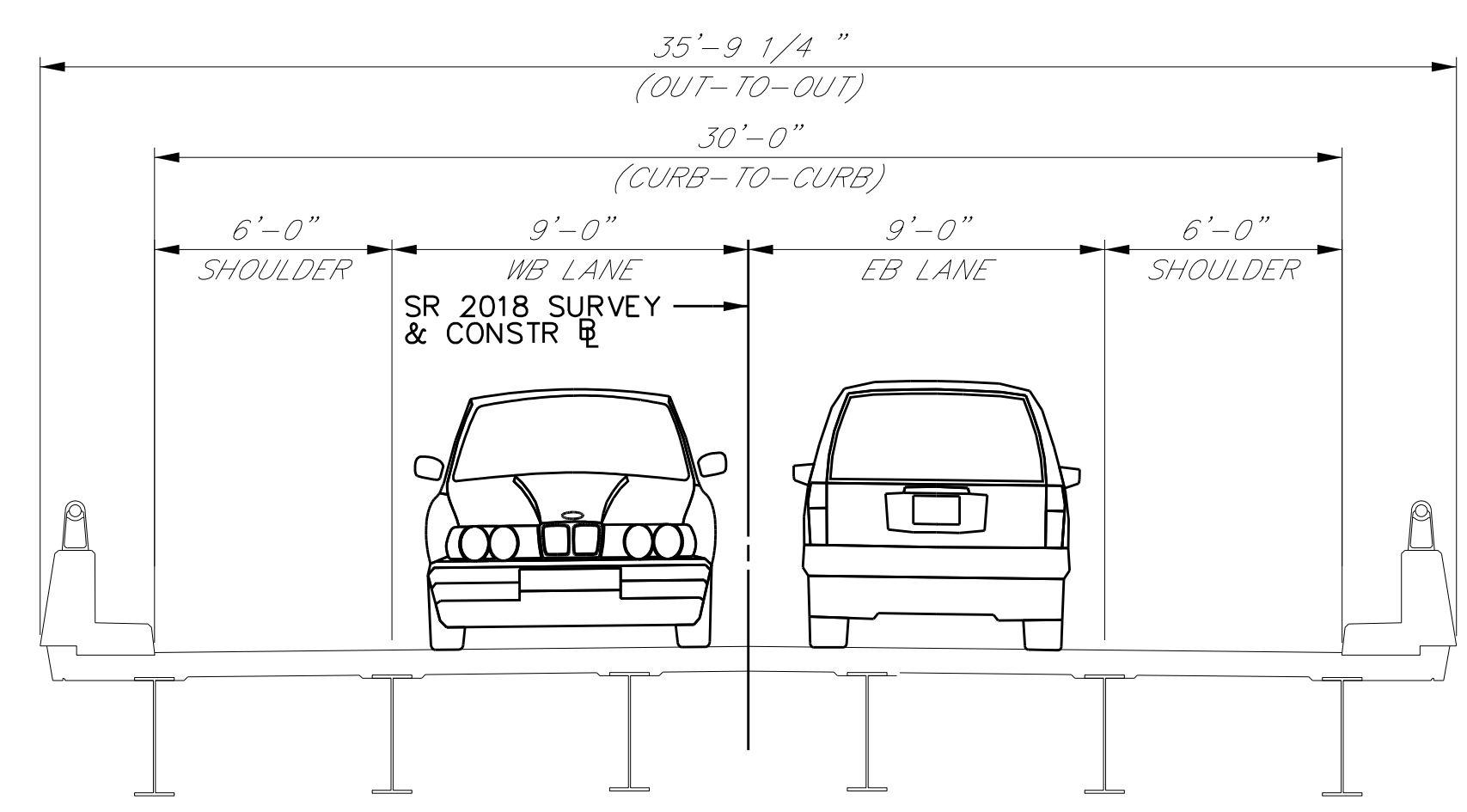


Legend

- PROPOSED ROADWAY
- PROPOSED SHOULDER
- PROPOSED SIDEWALK
- PROPOSED BRIDGE
- PARCEL - (AFFECTED)
- PARCEL - (NOT AFFECTED)
- EXISTING EMERGENCY MAINTENANCE RAMP
- PROPOSED CUT LINE
- PROPOSED FILL LINE
- LEGAL RIGHT-OF-WAY LINE
- REQUIRED RIGHT-OF-WAY
- DRAINAGE SYSTEM
- EXISTING RIGHT-OF-WAY FENCE
- PROPOSED RIGHT-OF-WAY FENCE

Anticipated Project Timeline

- ADVANCED UTILITY LOCATIONS: JULY 2022
- BID PROJECT: OCTOBER 2022
- BEGIN STAGE 1 CONSTRUCTION: FEBRUARY 2023
- BEGIN STAGE 2 CONSTRUCTION: NOVEMBER 2023
- COMPLETE CONSTRUCTION: NOVEMBER 2024

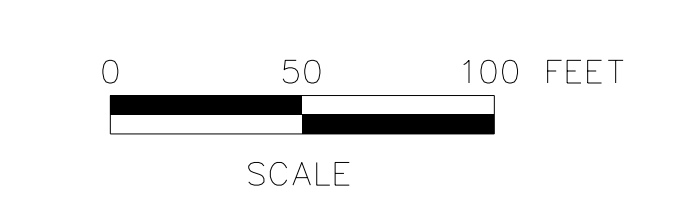

8/25/2021
 10/15/2015
 Project: SR 2018 Indian Creek Road Bridge Reconstruction Material: SR 2018 - NB-331 - Indian Creek Presentation Board.dgn